

# Ball Valve

WB-02TL

2-PC Stainless Steel Ball Valve  
Full Port, 1000WOG, PN63, Light Type

## FEATURES:

- Blow-out Proof Stem
- Investment Casting Body
- Pressure Balance Hole in Ball Slot
- Full Port
- Various Thread Standard Available
- Locking Device Available, **New Design**

## STANDARD:

- Design: ASME B16.34, API608
- Wall Thickness: ASME B16.34, GB12224
- Pipe Thread: ANSI B 1.20.1, BS 21/2779, DIN 259/2999, ISO 228
- Inspection & Testing: API 598

NO.	PARTS NAME	MATERIAL		
1	Body	CF8M	CF8	WCB
2	Body Gasket	PTFE		
3	Cap	CF8M	CF8	WCB
4	Ball Seat	PTFE	R-PTFE	
5	Ball	CF8M	CF8	
6	Thrust Washer	PTFE		
7	Stem Packing	PTFE		
8	Stem	SUS316	SUS304	
9	Gland Nut	SUS304		
10	Handle	SUS304		
11	Stem Nut	A194-8		
12	Pin	Plastic		
13	Locking Device	SUS304		
14	Handle Cover	Plastic		

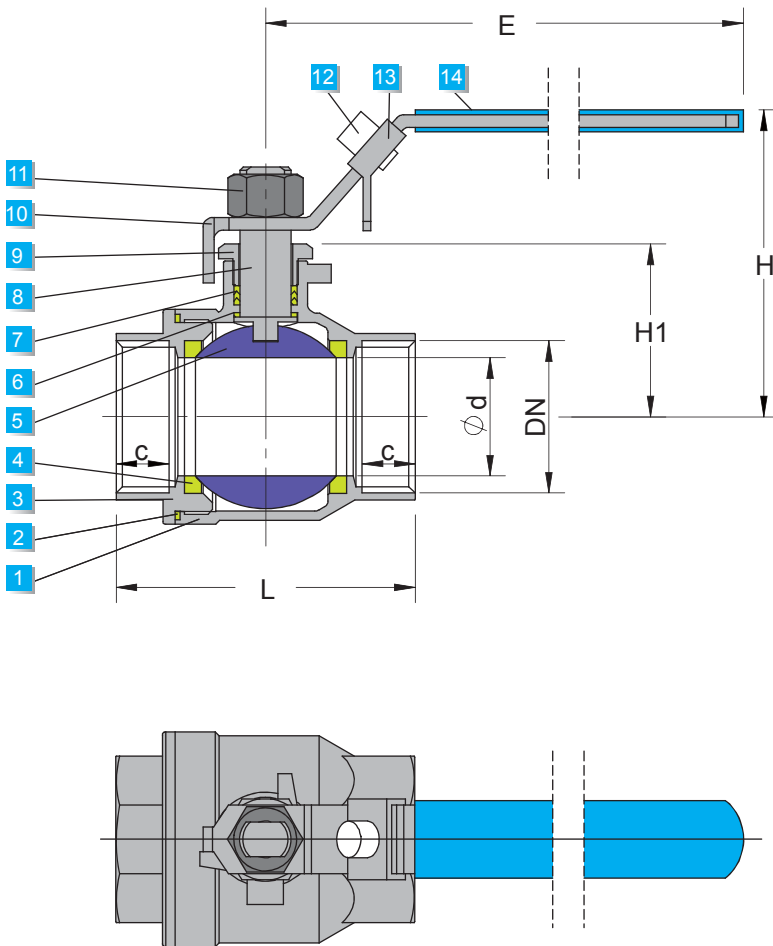

Unit:mm

DN	L	ød	H	H1	E	C	END
1/4"	46	10.5	51.5	20.5	98	10	BSP BSPT PT DIN NPT etc...
3/8"	46	10.5	51.5	20.5	98	10	
1/2"	53	14	59	24	98	12	
3/4"	62	20	67	30.5	120	13	
1"	73	24	70	33.5	120	15.5	
1-1/4"	87	31.5	80.5	41	150	17.5	
1-1/2"	96	38	94	50	170	18	
2"	108	48	102	58	170	18	
2-1/2"	138	64	125	72.5	250	24	
3"	164	76	135.5	83	250	27.5	