

## FEATURES:

- Face to Face:ANSI B16.10
- Investment Casting Body and Cap
- Flange End:ANSI B16.5
- Design Standard:API 600
- Testing Standard:API 598

NO.	PART NAME	MATERIAL
1	Body	A216 WCB
2	Seat	A105 HF
3	Wedge	WCB F6
4	Bolt	A193 B7
5	Gasket	PTFE
6	Cap	A216 WCB
7	Nut	A194 2H
8	Packing Seal	PTFE+Stainless Steel Wire
9	Gland	SUS 304
10	Stem	A276-420
11	Handle	60-40-18
12	Lock Nut	A108-1035
13	Stem Nut	Bronze
14	Nut	A192 2H
15	Eye Bolt	A193 B7
16	Stem Seat	A276 410

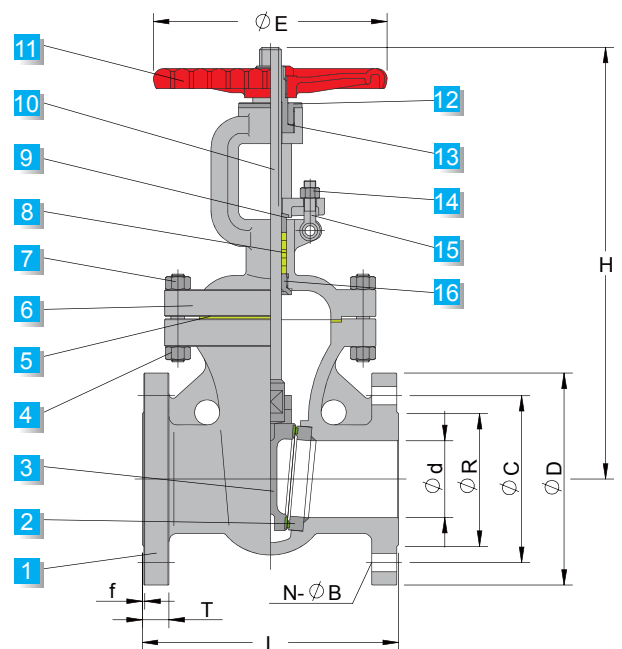

Unit:mm

Size	L	ød	øR	øC	øD	H	N	øB	T	f	øE
2"	216	51	92	127	165	420	8	19	23	1.6	200
2-1/2"	241	64	105	149	190	460	8	22	26	1.6	250
3"	283	76	127	168.5	210	528	8	22	29	1.6	250
4"	305	102	157	200	254	650	8	22	32	1.6	250
5"	381	127	186	235	279	700	8	22	35	1.6	300
6"	403	152	216	270	318	820	12	22	37	1.6	350
8"	419	203	270	330	381	985	12	25	42	1.6	450
10"	457	254	324	387.5	445	1190	16	29	48	1.6	500
12"	502	305	381	451	521	1430	16	32	51	1.6	550
14"	762	337	413	514.5	584	1560	20	32	54	1.6	580
16"	838	387	470	571.5	648	1760	20	35	58	1.6	580
18"	914	432	533	628.5	711	1940	24	35	61	1.6	620
20"	993	483	584	686	775	2145	24	35	64	1.6	620