

FEATURES:

- Face to Face:ANSI B16.10
JIS B2002
- Investment Casting Body and Cap
- Flange End:ANSI B16.5
JIS B2339
- Design Standard:API 603
- Testing Standard:API 598

NO.	PART NAME	MATERIAL	
1	Body	CF8M	CF8
2	Disc	CF8M	CF8
3	Bolt	A193-B8	
4	Nut	A193-B8	
5	Body Gasket	SUS 301 GRAPHITE	
6	Cap	CF8M	CF8
7	Back Seat	SUS 304	
8	Stem Packing	PTFE	
9	Gland	SUS 304	
10	Wheel Handle	FCD	
11	Stem	SUS 316	SUS 304
12	Stem Nut	SUS 304	
13	Stop Gland	SUS 304	
14	Nut	A193-B8	
15	Eye Bolt	SUS 304	
16	Stop Pin	SUS 301	

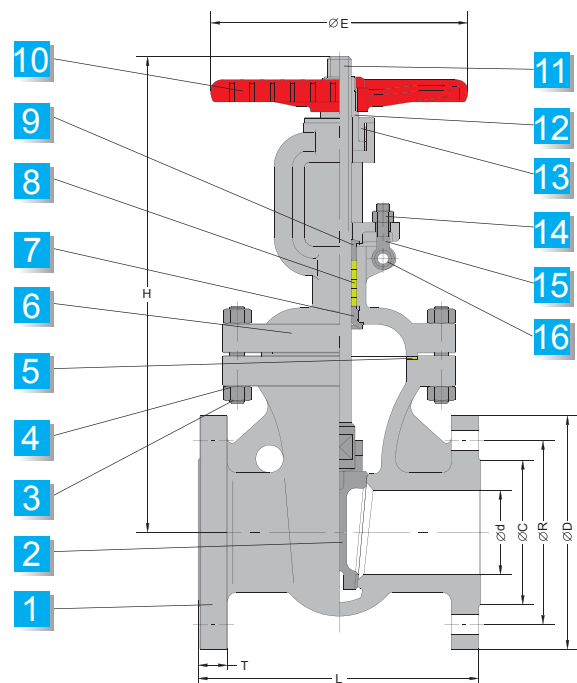

Unit:mm(20K/300LB)

Size	L	H	ød	øC		øR		øD		T		E
				20K	300LB	20K	300LB	20K	300LB	20K	300LB	
1/2"	140	230	15	51	35	70	66.5	95	95	14	14.3	120
3/4"	152	230	20	56	43	75	82.5	100	117	16	15.9	120
1"	165	230	25	67	51	90	89	125	124	16	17.5	200
1-1/2"	190	350	40	81	73	105	114.5	140	156	18	20.7	250
2"	216	380	50	96	92	120	127	155	165	18	22.3	250
2-1/2"	241	455	65	116	105	140	149	175	190	20	25.4	250
3"	283	500	78	132	127	160	168	200	210	22	28.6	250
4"	305	610	95	160	157	185	200	225	254	24	31.8	300
5"	381	635	125	195	186	225	235	270	279	26	35	300
6"	403	795	150	230	216	260	270	305	318	28	36.6	350
8"	419	1005	200	275	270	305	330	350	381	30	41.3	400
10"	457	1250	250	345	324	380	387.6	430	444	34	47.7	500
12"	502	1500	300	395	381	430	451	480	521	36	50.8	500