

# Gate Valve

WG-A01FC, WG-J01FC

Gate Valve 10K/150LB Flange End (A216 WCB)

## FEATURES:

- Face to Face: ANSI B16.10
- Flange End Standard: ANSI B16.5
- Design Standard: ANSI B16.34
- Testing Standard: API 598
- Investment Casting Body and Cap

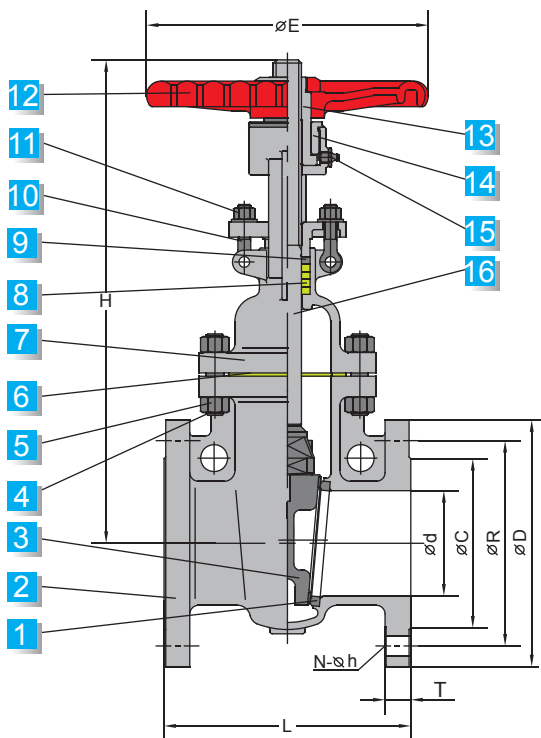

NO.	PART NAME	MATERIAL
1	Seat	A105 HF
2	Body	A216 WCB
3	Disc	A216 WCB+F6
4	Bolt	A193 B7
5	Nut	A194 2H
6	Body Gasket	FLEXIBLE GRAPHITE
7	Cap	A216 WCB
8	Stem Packing	PTFE+Stainless Steel
9	Gland	SUS 304
10	Eye Bolt	A193 B7
11	Nut	A194 2H
12	Handle	60-40-18
13	Stem Nut	D-2
14	Gland	A29 1035
15	Oil Filler	A570 GR.A
16	Stem	A182 F6

Unit:mm

Size	L	H	øE	ød	øC	øR	øD	T	N	øh
1/2"	108	188	90	15	35	60.5	89	11.2	4	15
3/4"	117	202	90	20	43	70	98	11.2	4	15
1"	127	225	100	25	51	79.5	108	11.2	4	15
1-1/2"	165	362	200	40	73	98.5	127	14.3	4	16
2"	178	409	200	50	92	120.5	152	15.9	4	19
2-1/2"	190	465	200	65	105	139.5	178	17.5	4	19
3"	203	510	250	80	127	152.5	190	19.1	4	19
4"	229	550	250	100	157	190.5	229	23.9	8	19
5"	254	590	300	125	186	216	254	23.9	8	22
6"	267	630	300	150	216	241.5	279	25.4	8	22
8"	292	950	350	200	270	298.5	343	28.6	8	22
10"	330	1150	400	250	324	362	406	30.2	12	25
12"	356	1350	450	300	381	432	483	31.8	12	25
14"	381	1500	500	350	413	476	533	35	12	29
16"	406	1720	600	400	470	539.5	597	36.6	16	29
18"	432	1900	-	440	533	578	635	39.7	16	32
20"	457	2110	-	490	584	635	699	42.9	16	32